

SERVOPLUS® Couplings

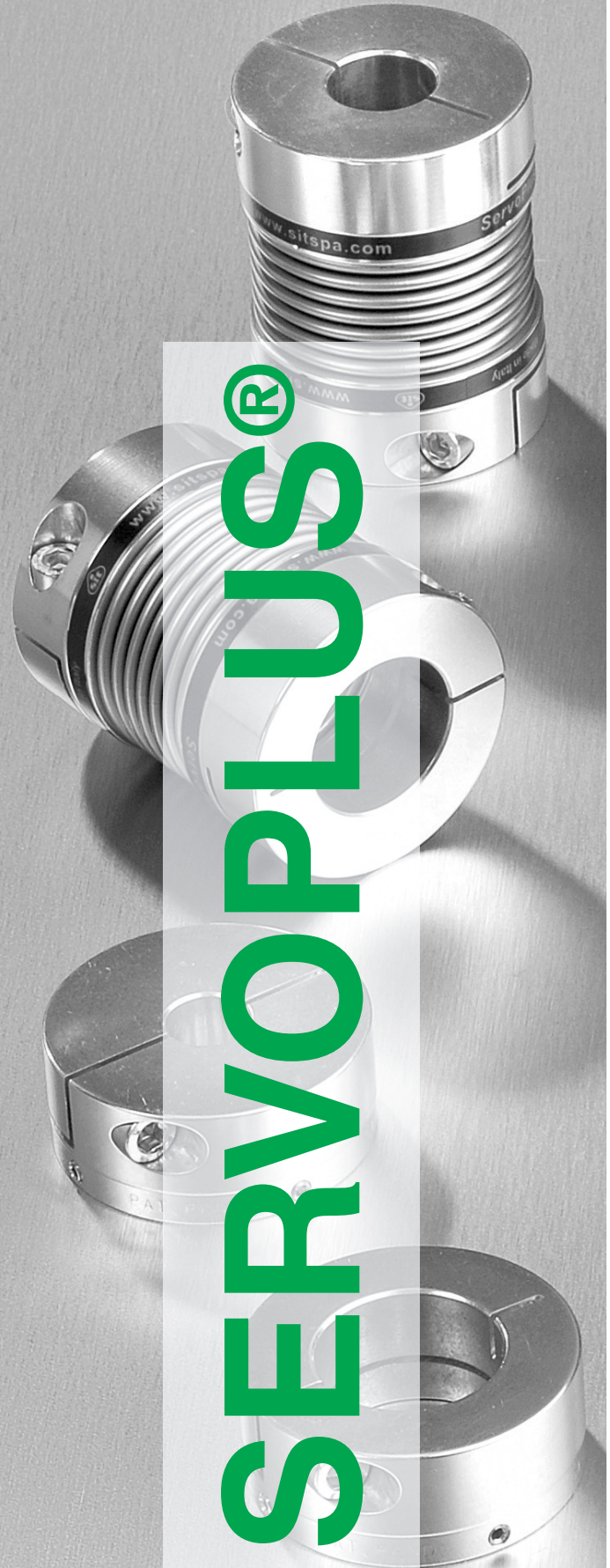

SERVOPLUS®

SERVOPLUS® couplings

Description

SERVOPLUS® bellow couplings are the perfect coupling in all servo motor applications where high torsional rigidity, truly backlash free torque transmission, low inertia, and superior

reliability are required. The innovative modular system allows quick delivery and competitive cost advantage.

SERVOPLUS® couplings feature:

- backlash free for highest torque transmission precision
- low moment of inertia
- excellent dynamic characteristics for superior drives at high speed and torque inversions
- allow for axial, radial and angular misalignment
- easy mounting
- high torsional rigidity
- wear and maintenance free
- working temperature up to 300 °C
- innovative modular execution

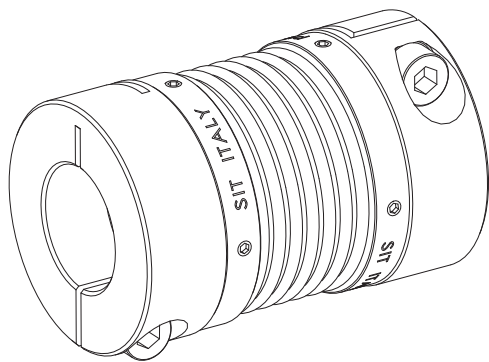

PAT. APPL. FILED

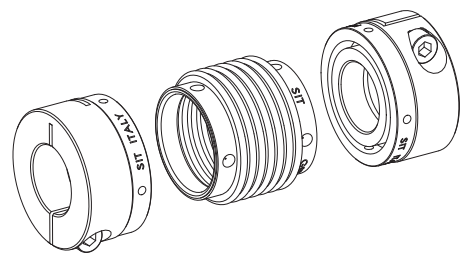

SERVOPLUS®

SERVOPLUS® high tech bellow couplings

The innovative modular system allows competitive costs and very quick delivery for any shaft combination. Additional benefits include bellow replacement without moving shaft.



Standard execution

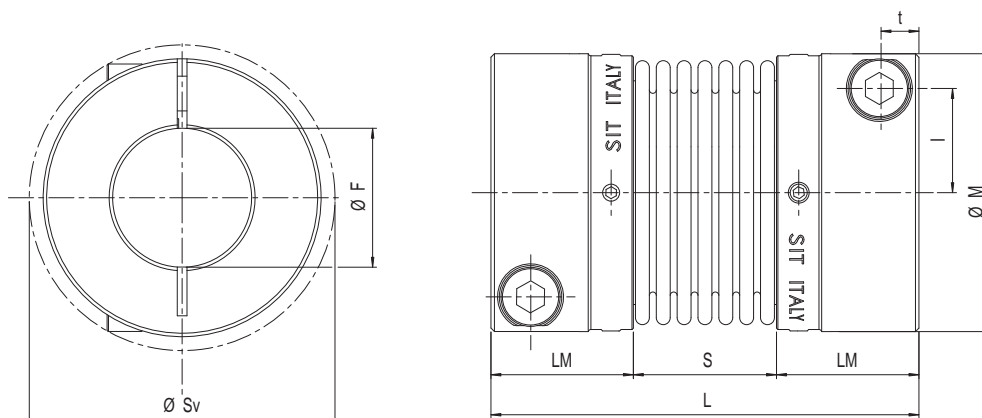

Type	Dimensions [mm]							Screws			Socket set screws		Technical data											
	F		M	S _V	L _M	S	L	Tipo	t	l	M _s [Nm]	Tipo	M _s [Nm]	T _{KN} [Nm]	T _{Kmax} [Nm]	N _{max} [min ⁻¹]	Moment of inertia [x10 ⁻⁶ Kg·m ²]	Torsional rigidity C _T [Nm/rad]	Axial spring stiffness [N/mm]	Radial spring stiffness [N/mm]	Misalignment			W* [kg]
	min	max																			Δka	Δkr	Δkw	
16	5	16	34	36	17	16,5	50,5	M4	4,5	12	2,9	M3	0,8	5	10	14000	14	3050	29	92	±0.5	0,2	1,5	0,082
20	8	20	40	44	20,5	21	62	M5	5,5	15	6	M3	0,8	15	30	11900	34	6600	42	126	±0.6	0,2	1,5	0,135
30	10	30	55	58	22,5	27	72	M6	6,5	20	10	M4	2	35	70	8700	140	14800	65	155	±0.8	0,25	2	0,289
38	14	38	65	73	26	32	84	M8	8	25	25	M4	2	65	130	7300	310	24900	72	212	±0.8	0,25	2	0,438
45	14	45	83	89	31	41	103	M10	9,5	30	49	M5	3,8	150	300	5800	1056	64000	88	492	±1	0,3	2	0,924

*= with max bore

SERVOPLUS® coupling																								
Type	Bore range and dampening hub transmissible torque [Nm]																							
	5	6	7	8	9	10	11	12	14	15	16	18	19	20	24	25	28	30	32	35	38	40	42	45
16	4,9	5,9	6,9	7,8	8,8	9,8	10,8	11,8	13,7	14,7	15,7													
20				12,8	14,4	16	17,6	19,2	22,3	23,9	25,5	28,7	30,3	31,9										
30							24,9	27,1	31,7	33,9	36,2	40,7	43	45,2	54,3	56,5	63,3	67,9						
38												74,6	78,8	82,9	99,5	104	116	124	133	145	158			
45														132	158	165	184	198	211	231	250	263	277	296

Additional hub executions available upon request:

- conical clamping bush
- conical bore for FANUC motors

M _S	Screw tightening torque	Nm
T _{KN}	Coupling nominal torque	Nm
T _{Kmax}	Coupling maximum torque	Nm
n _{max}	Maximum rpm	min ⁻¹
C _T	Torsional rigidity	Nm/rad
ΔK _a	Maximum axial misalignment	mm
ΔK _r	Maximum radial misalignment	mm
ΔK _w	Maximum angular misalignment	°
W	Weight	kg

Order form

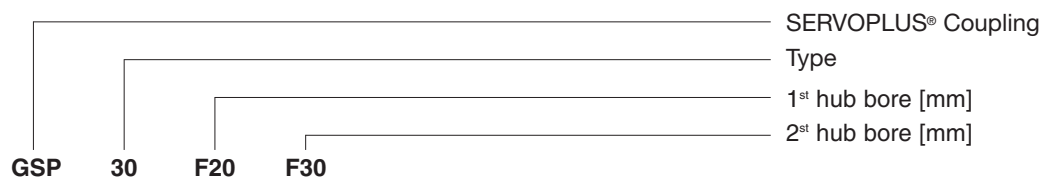

Coupling selection

Verify the torque to be transmitted

The torque transmissible by the coupling T_{KN} must always be higher than the maximum torque applied to the driver and driven shaft.

Being:

T_{AS} = peak torque of motor side (Nm)
 T_{LS} = peak torque of driven side (Nm)
 k = service factor

$$T_{KN} \geq k \cdot T_{AS/LS}$$

Verify acceleration torque

T_s = acceleration torque (driver or driven side)

The nominal torque must be higher than the acceleration torque.

$$T_{KN} > T_s \cdot k$$

T_s = $T_{AS} \cdot m_A$
 T_s = $T_{LS} \cdot m_L$

$$\text{With: } m_A = \frac{J_A}{J_A + J_L} \quad m_L = \frac{J_L}{J_A + J_L}$$

$k = 1,5$ with uniform load
 $k = 2$ with non-uniform load
 $k = 2,5 - 4$ with peak or impact load

For drives in machine tools $k = 1,5 - 2$

For applications with extreme precision requirements it could be important to verify the transmission error which is calculated as follows:

$$\beta = \frac{180 \cdot T_{AS}}{\pi \cdot C_T} [^\circ]$$

With C_T = torsional stiffness of the coupling [Nm/rad]

Verify shaft diameter

After having selected the coupling verify the required shaft diameters are compatible with the selected coupling size (F_{min}/F_{max}).

Verify misalignment

Misalignment in the application must be compatible with the allowable misalignment of the coupling. It must be considered that the maximum values of misalignment of the coupling can not be reached simultaneously.

Given the values of misalignment of the application and converted in percentage with respect to the corresponding maximum values of the coupling, the percentage sum must not exceed 100%.

$$\text{With: } \frac{\Delta k_{aM}}{\Delta k_a} \cdot 100\% + \frac{\Delta k_{rM}}{\Delta k_r} \cdot 100\% + \frac{\Delta k_{wM}}{\Delta k_w} \cdot 100\% < 100\%$$

• Δk_aM , Δk_rM , Δk_wM respectively axial, radial, and angular misalignment of the machine

• Δk_a , Δk_r , Δk_w respectively axial, radial, and angular misalignment which the coupling can bear

- **axial misalignment:** usually due to temperature variation
- **angular misalignment:** values up to 2° are acceptable
- **radial misalignment:** pay close attention not to exceed maximum radial misalignment. It could bring to bellow distortion.

Verify hub transmissible torque

It is important to verify the torque required in the drive is compatible with the transmissible load of the hub-shaft connection. It is possible to deliver coupling with different clamping system in case special application is needed. Also it is possible to deliver couplings with minimum bore smaller than indicated in catalogue. In such a case, the hub shaft connection transmissible torque will be lower.

Technical features

Long lasting

SERVOPLUS® couplings are designed for an infinite number of cycles when the maximum misalignment values and peak torque are respected.

Peak torque

SERVOPLUS® couplings allow for short periods a peak torque equal to the double of the nominal torque. The hub shaft connection must be correctly dimensioned.

Bearing load

Due to flexibility in handling axial, angular and radial misalignment, SERVOPLUS® couplings allow reduced bearing load which reduces maintenance cost.

Working temperature

SERVOPLUS® couplings may be used up to 300°C without limitation.

Maintenance and wear

SERVOPLUS® couplings are wear and maintenance free.

Mounting instructions

SERVOPLUS® couplings are delivered with finished bore and ready for installation.

- carefully clean the contact surfaces
- position the coupling on the shafts ends and carefully tighten the radial clamping screws to the indicated torque T_A

Dismounting

- loosen radial screws
- pull apart the drive and remove the coupling

The special design of the SERVOPLUS® coupling allows the removal of the coupling or the bellow replacement without pulling apart the drive.

- loosen the socket screws
- loosen the radial clamping screws
- move the clamping hubs on the shafts
- remove the clamping hubs

Shaft requirements for a safe torque transmission are:

- tolerance h6
- roughness $R_{tmax} 16\mu$

Note

It is recommended to pay careful attention during the mounting and dismounting operation. Damaging the bellow may render coupling unusable.

Safety norms

All rotating parts must be protected against any possibility of contact with people.

Protection must be designed so that even in case of coupling breakage, no damage can be done to people and equipment.